

Spring supports Type 29

Spring supports type 29 C2 19 to 29 93 18

Standard design,
delivery from stock.

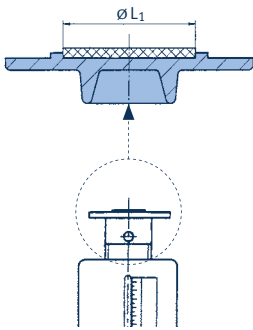

Load plate with integrated
slide plate.

When using slide plates the sliding surfaces of the counter component used should be fitted with stainless steel plating. This is indicated by the suffix 'SP' on the type designation (e.g. clamp base type 49 22 25-SP).

type 29* with slide plate		$\varnothing L_1$
up to 180°C	up to 350°C	
29 C2 17	29 C2 16	40
29 D. 17	29 D. 16	40
29 1. 17	29 1. 16	40
29 2. 17	29 2. 16	40
29 3. 17	29 3. 16	40
29 4. 17	29 4. 16	65
29 5. 17	29 5. 16	65
29 6. 17	29 6. 16	110
29 7. 17	29 7. 16	110
29 8. 17	29 8. 16	150
29 9. 17	29 9. 16	150

* friction values of the sliding components, see table on p. 7.11.

For large horizontal load displacements, beside the use of slide plates the use of clamp bases with twist-off restraints is also recommended.

Order details:
spring supports type 29 ...
marking: ...
set load: ...kN
travel: ...mm up/down

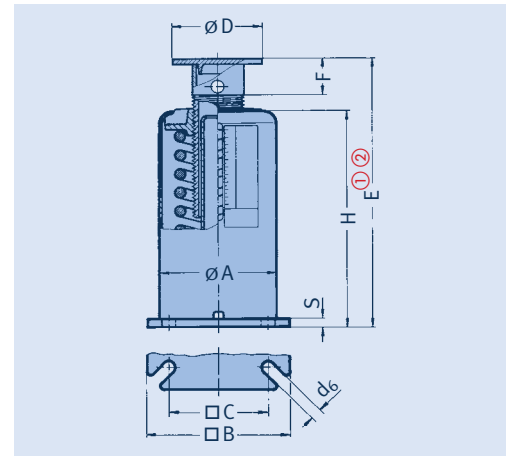

type ②	$\varnothing A$	$\square B$	$\square C$	d_6	E ①②	F	H	$\varnothing D$	S	weight [kg]
29 C2 19	80	105	75	10	270	36	210	80	6	2.6
29 D1 19	90	125	95	12	195	36	145	80	8	3.2
29 D2 19	90	125	95	12	305	36	245	80	8	4.3
29 D3 19	90	125	95	12	550	36	470	80	8	6.6
29 11 18	90	125	95	12	195	36	145	80	8	3.4
29 12 18	90	125	95	12	305	36	245	80	8	4.6
29 13 18	90	125	95	12	550	36	470	80	8	7.2
29 21 18	115	150	115	14	200	36	150	100	10	5.6
29 22 18	115	150	115	14	310	36	250	100	10	7.6
29 23 18	115	150	115	14	540	36	460	100	10	11.1
29 31 18	115	150	115	14	205	36	155	100	12	6.3
29 32 18	115	150	115	14	310	36	250	100	12	8.4
29 33 18	115	150	115	14	550	36	470	100	12	13.0
29 41 18	155	190	140	18	240	48	180	120	12	11.9
29 42 18	155	190	140	18	360	48	290	120	12	16.0
29 43 18	155	190	140	18	615	48	525	120	12	25.0
29 51 18	180	220	170	18	270	50	210	150	12	20.0
29 52 18	180	220	170	18	370	50	300	150	12	24.3
29 53 18	180	220	170	18	625	50	535	150	12	37.0
29 61 18	220	260	200	23	305	50	245	170	15	34.0
29 62 18	220	260	200	23	430	50	360	170	15	44.0
29 63 18	220	260	200	23	730	50	640	170	15	68.0
29 71 18	245	290	215	23	360	52	300	200	20	53.0
29 72 18	245	290	215	23	500	52	425	200	20	68.0
29 73 18	245	290	215	23	790	52	695	200	20	97.0
29 81 18	245	290	215	27	400	55	335	200	20	60.0
29 82 18	245	290	215	27	575	55	500	200	20	84.0
29 83 18	245	290	215	27	965	55	870	200	20	133.0
29 91 18	275	340	255	33	440	60	370	240	25	91.0
29 92 18	275	340	255	33	625	60	545	240	25	118.0
29 93 18	275	340	255	33	1010	60	910	240	25	173.0

① Dimension 'E' is independent of the load adjustment; it changes on loading by the respective spring travel (see load table on p. 2.5). Adjustment possibility + 30mm.

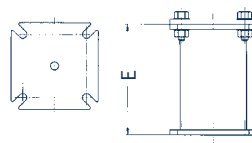

② Type 29 is supplied as standard with a galvanized load plate without a slide plate. If slide plates are used, the 'E' dimension increases by 2.5mm. Please note table above. See also p. 7.12.

type 29 .9 15-E...
load group



To bridge greater installation heights, adapted extensions can be ordered.