

Spring hangers Type 21

Spring hanger type 21 C2 19 to 21 95 18

Standard design,
delivery from stock.

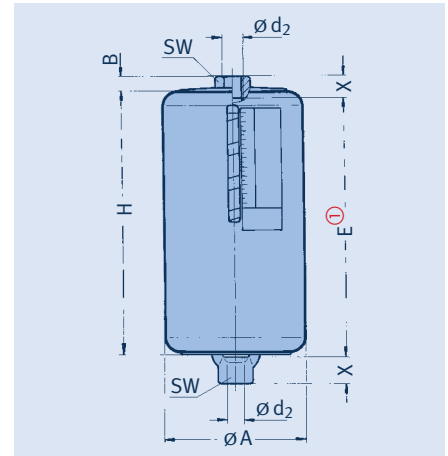

① Dimension 'E' increases on loading by the corresponding spring travel (see load table on p. 2.5).

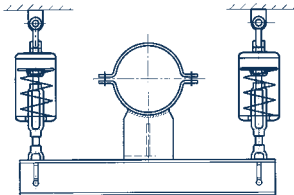

In restricted spaces the spring hangers can be used with type 79 trapezes (see p. 2.14).

type	$\varnothing A$	B	$\varnothing d_2$	E ①	H	SW	X	weight [kg]
21 C2 19	80	11	M10	205	205	19	15	1.9
21 D2 19	90	11	M10	250	245	19	15	3.0
21 D3 19	90	11	M10	475	470	19	15	5.0
21 11 18	90	11	M12	155	145	19	15	2.1
21 12 18	90	11	M12	250	245	19	15	3.1
21 13 18	90	11	M12	475	470	19	15	5.5
21 21 18	115	12	M12	155	150	19	15	3.8
21 22 18	115	12	M12	255	250	19	15	5.3
21 23 18	115	12	M12	475	460	19	15	8.6
21 31 18	115	13	M16	160	155	24	20	4.3
21 32 18	115	13	M16	255	250	24	20	6.0
21 33 18	115	13	M16	475	470	24	20	9.7
21 34 18	115	13	M16	840	725	24	20	14.0
21 41 18	155	17	M20	185	180	30	25	9.2
21 42 18	155	17	M20	290	290	30	25	12.8
21 43 18	155	17	M20	525	525	30	25	20.0
21 44 18	155	17	M20	920	800	30	25	29.0
21 51 18	180	21	M24	215	215	36	30	16.5
21 52 18	180	21	M24	305	305	36	30	20.5
21 53 18	180	21	M24	540	540	36	30	32.0
21 54 18	180	21	M24	1035	825	36	30	46.0
21 55 18	180	21	M24	1275	1065	36	30	57.0
21 61 18	220	24	M30	245	245	46	35	31.0
21 62 18	220	24	M30	360	360	46	35	40.0
21 63 18	220	24	M30	640	640	46	35	62.0
21 64 18	220	24	M30	1205	980	46	35	90.0
21 65 18	220	24	M30	1490	1265	46	35	114.0
21 71 18	245	30	M36	280	285	55	45	48.0
21 72 18	245	30	M36	405	410	55	45	63.0
21 73 18	245	30	M36	675	680	55	45	89.0
21 74 18	245	30	M36	1300	1070	55	45	133.0
21 75 18	245	30	M36	1575	1345	55	45	160.0
21 81 18	245	30	M42	305	320	65	50	58.0
21 82 18	245	30	M42	470	485	65	50	80.0
21 83 18	245	30	M42	845	860	65	50	126.0
21 84 18	245	30	M42	1430	1330	65	50	182.0
21 85 18	245	30	M42	1810	1710	65	50	228.0
21 91 18	275	36	M48	330	355	75	60	84.0
21 92 18	275	36	M48	505	530	75	60	111.0
21 93 18	275	36	M48	870	895	75	60	164.0
21 94 18	275	36	M48	1515	1395	75	60	243.0
21 95 18	275	36	M48	1885	1765	75	60	296.0

Order details:

spring hangers type 21 ...
 marking: ...
 set load: ...kN
 travel: ...mm up/down